



HomePlug & ARRL Joint Test Report
January 24, 2001
Testing Conducted December 13, 14, 2000

Representatives from HomePlug and ARRL performed joint testing of HomePlug's proposed waveform and power spectral density (PSD) limits at ARRL headquarters and a nearby site on December 13 and 14, 2000. This work was conducted in cooperation under non-disclosure agreement to ensure that the HomePlug power line technology minimizes instances of harmful interference to licensed amateur radio operators.

Participants

Bruce Denton	Intellon
David Fifield	Broadcom
Steve Gardner	Conexant
Ed Hare	ARRL
Brian Markwalter	Intellon

HomePlug Background

For those who may read this report that are not HomePlug members, the HomePlug Powerline Alliance (HomePlug) is a not-for-profit corporation formed to provide a forum for the creation of open specifications for high speed home powerline networking products and services. It also seeks to accelerate the demand for these products and services through the sponsorship of market and user education programs.

ARRL Background

ARRL is the national membership association for Amateur Radio operators. Today ARRL, with approximately 163,000 members, is the largest organization of radio amateurs in the United States. The ARRL is a not-for-profit organization that:

- promotes interest in Amateur Radio communications and experimentation
- represents US radio amateurs in legislative matters, and
- maintains fraternalism and a high standard of conduct among Amateur Radio operators.

Testing

The signal source for testing was the "standard" HomePlug signal available at the time of testing. Since ICs were not yet available to generate the signal in real time, three HomePlug frames with random data were generated mathematically and synthesized by an arbitrary waveform generator.

The complete signal source is shown in Figure 1. The waveform file of three frames is stored in the Tektronix 2021. The 2021 output goes through a Mini-circuits ZHL-3A-BNC amplifier. The output of the amplifier goes to a BNC T connector with one side containing a 50 Ohm resistive load and the other connected to a power line coupler. The coupler is a 1:1 transformer with a blocking capacitor for line voltage. The 50 Ohm termination serves to pre-load the output so that the source impedance is closer to what HomePlug believes typical products will be.

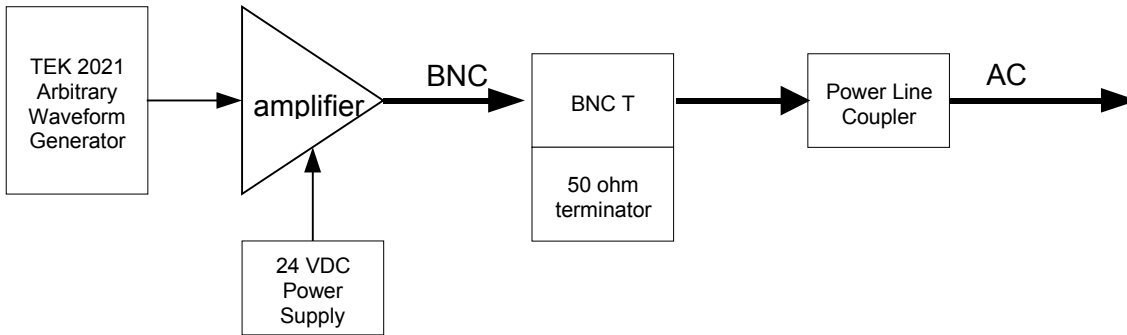

Figure 1. HomePlug Test Signal Source.

The spectral mask of the test signal meets the mask shown in Figure 2. Calibration was accomplished by connecting the signal source to a Rhode & Schwartz ESH2 receiver. The amplitude of the 2021 was adjusted to achieve a quasi-peak reading of between -50 and -51 dBm/Hz on the ESH2. For the high signal level. The notches spanning the amateur radio bands are 30 dB below this level.

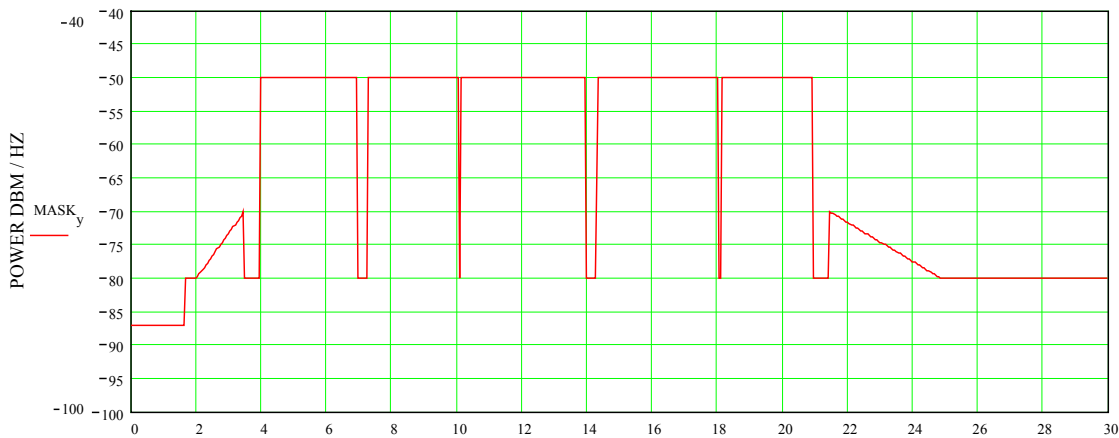

Figure 2. Test Signal PSD Mask

A quick measurement was made at W1AW to confirm the signal source. The source was connected to the ARRL headquarters' power line. The ESH2 was tuned to verify that the signal could be detected outside the amateur radio bands where the injection level was -50 dBm/Hz. A measurement was made at 6.512 MHz (outside the Ham bands) of an 8 dB increase in signal level, verifying proper injection of the signal.

A series of measurements were then made using two antennas at W1AW. These results are contained in Table 1. The table shows the measurement frequency, a reading in dBuV with the HomePlug signal off, reading in dBuV with the HomePlug signal on, comment on audibility, and the antenna used for the measurement. All measurements were made using a quasi-peak detector and 10 kHz bandwidth. Shaded rows are amateur radio frequencies where the HomePlug signal limit is -80 dBm/Hz.

Table 1. Measured Results at W1AW

Frequency	Off signal level	On signal level	Audibility	Antenna
3.00 MHz	20 dBuV	20 dBuV	Barely audible	dipole
3.60 MHz	30 dBuV	30 dBuV	Barely audible	dipole
6.54 MHz	25 dBuV	28 dBuV	Audible	dipole
7.10 MHz	26 dBuV	26 dBuV	Inaudible	dipole
9.65 MHz	23 dBuV	34 dBuV	Audible	dipole
10.12 MHz	14 dBuV	14 dBuV	Inaudible	dipole
13.55 MHz	20 dBuV	20 dBuV	Barely audible	Triband Yagi
14.04 MHz	25 dBuV	25 dBuV	Inaudible	Triband Yagi
18.10 MHz	19 dBuV	19 dBuV	Inaudible	Triband Yagi

The second day, testing was performed at a single family dwelling, hosted by Paul Shafer, KB1BE. A quick measurement was made with the ESH2 connected to a PB5EM antenna pointed toward the house. Ambient signal level was measured at 6 dBuV QP (frequency not recorded). An increase of 2 dBuV was noted with the HomePlug signal on. (Anecdotally, a signal level of 20 dBuV was recorded when a fluorescent light in the next room was turned on.) An on/off comparison was made at 21.04 MHz. Both showed a reading of 8 dBuV, and the HomePlug signal was barely audible.

A second set of measurements was made with a Moregain folded dipole antenna. The antenna was located on a mast approximately 40 feet high with one end approximately 10 feet from the house. The signal was injected in a basement outlet near the radio rig. Results are shown in Table 2.

Table 2. Measured Results at KB1BE with Folded Dipole

Frequency	Off signal level	On signal level	Audibility	Comments
10.13 MHz	12 dBuV	12 dBuV	Inaudible	
9.68 MHz	NA	26 dBuV		Not a ham band
7.02 MHz	14 dBuV	14 dBuV	Inaudible	
6.7 MHz	NA	19 dBuV		Not a ham band
3.97 MHz	15 dBuV	15 dBuV	Just audible	

A third set of measurements were made with a sloper antenna. The antenna was mounted on the same mast as the others at a height of 45 feet. One end of the antenna was anchored to the house. It was noted after the tests that the antenna terminated less than 10 feet from the service entrance to the house. Various outlet locations were measured as noted in the results found in Table 3.

Table 3. Measured Results at KB1BE with Sloper Antenna

Frequency	Off signal level	On signal level	Audibility	Comments
3.97 MHz	12 dBuV	16 dBuV	Barely audible	
7.00	Not taken	Not taken	Inaudible	
14.00 MHz	6 dBuV	12 dBuV	Audible	Living room outlet
7.00 MHz	7 dBuV	14 dBuV	Audible	Living room outlet
7.00 MHz	NA	NA	Inaudible	Kitchen outlet (only grounded receptacle)
7.00 MHz	6 dBuV	12 dBuV	Audible	Second living room outlet
7.00 MHz	7 dBuV	14 dBuV	Audible	N.E. bedroom outlet

The afternoon of the second day, more testing was conducted at ARRL headquarters at station W1AW. The HomePlug signal was injected upstairs in the main radio equipment building with antennas located approximately 60 feet away. In a quick scan of the Ham bands, the HomePlug signal could not be detected at W1AW.

Conclusion

Tests showed in general that with moderate separation of the antenna from the structure containing the HomePlug signal that interference was barely perceptible. The cases of objectionable interference were noted for the sloper antenna at KB1BE in which the antenna was physically close to the power lines. Although this location was chosen to mimic as much as possible a situation in which the HomePlug equipment is in one house and the amateur radio in another, the very close location of the antenna termination to the service entrance made this comparison impossible. It was agreed that further testing was desirable at other stations, preferably in which either the HomePlug signal could be injected in the neighbor's house or in which the antenna was mounted 30 feet or more from the house.